

# MGP New Compact Tri-rod Cylinder (Ø20 ~ Ø100)



The way to automation

Cylinder  
Sizing  
SI  
SI A.  
SC / SU  
SCT  
SC A.  
DSN  
DSN A.  
MA  
MAL  
MA/MAL A.  
SDA  
CQ2  
CJ2  
CDU  
TN  
CXS  
MGP  
MSQ

## Features

- Light weight and compact.
- Strong transverse load capacity.
- Strong torque capacity.
- High Non-rotating precision.
- Both ball joint or slide joint are available for directional bearing for directional rod.
- Easy for installation.
- Position of both side ports are changeable.



## Ordering Code

<b>MGPM</b>	<b>32</b>	<b>50</b>	<b>MT</b>
Type Bearing	Bore	Stroke	Sensor
M: Slidable bearing	10 50		Blank: Without sensor
L: Ball bearing	20 75		* To choose proper sensor switch, please refer to stroke/ sensor switch chart.
	30 100		
	40		

## Ordering Code: (examples)

- Cylinder dia needed: 12 , stroke: 50, slid able bearing.  
Right model number: MGPM 12-50
- Cylinder dia needed: 40, stroke: 100 , Ball bearing with two sensor switches, lead wire length 0.5 m.  
Right model number: MGPM 40-100-Z73

## Specification

Bore (mm)	12	16	20	25	32	40	50	63	80	100
Operation Fluid	Air									
Operation	Double Acting									
Anti-pressure testing pressure	1.5 MPa (15.3 kgf/cm <sup>2</sup> )									
Max. Operation Pressure	1.0 MPa (10.2 kgf/cm <sup>2</sup> )									
Min. Operation Pressure	0.12 MPa (1.2 kgf/cm <sup>2</sup> )									
Ambient and fluid temperature	-10 ~ +60 °C									
Piston Velocity	50~500 mm/s								50~400 mm/s	
Buffer	Rubber Buffer									
Stroke Tolerance	+1.5 mm 0									
*Lubrication	Non-lub									
Bearing	Slidable bearing/Ball Bearing									
Non-rotating rod precision	Slidable bearing	± 0.08°	± 0.07°	± 0.06°	± 0.05°	± 0.04°				
	Ball Bearing	± 0.10°	± 0.09°	± 0.08°	± 0.06°	± 0.05°				
Port Size Rc (PT)	M5 x 0.8			1/8"		1/4"		3/8"		

\* If lubricant is demanded, please choose clear No.1 lubricant, ISOVG32.

## Stroke

Bore (mm)	Standard Stroke (mm)	** Sensor Switch Optional Model (For slide installation)
12 , 16	10 , 20 , 30 , 40 , 50 , 75 , 100	D-Z73L D-Z76L D-Z80L D-Y59AL D-Y59BL
20 , 25	20 , 30 , 40 , 50 , 75 , 100 , 125 , 175 , 200	
32 , 40 , 50 , 63 , 80 , 100	20 , 50 , 75 , 100 , 125 , 150 , 175 , 200	

\* Strokes ( from 5, 10, 20, 30, 35..... ) are added with 5, 10, 15, 20 mm thick gasket respectively, ex: MGPM50-10 is with 15 mm thickness gasket (MGPM50-25).

\*\* Please refer to sensor switch series pages in this catalog for spec. and characteristic. Code for lead wire length as follow:  
Blank - 0.5 m, L-3 m. Example: D-Y59AL, D-Y59AL.

## Load and Torque

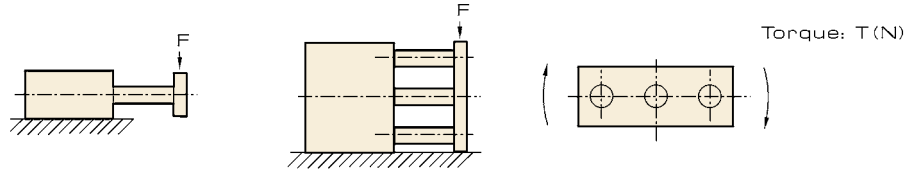

Bore (mm)	Series	Max. Transverse Load F (N)											
		Stroke (mm)											
		10	20	25	30	40	50	75	100	125	150	175	200
12	MGPM	24	19	-	17	14	13	26	22	-	-	-	-
	MGPL	37	27	-	22	35	30	23	18	-	-	-	-
16	MGPM	38	31	-	27	23	21	37	32	-	-	-	-
	MGPL	54	40	-	32	54	47	35	28	-	-	-	-
20	MGPM	-	49	-	43	38	35	87	75	66	59	54	49
	MGPL	-	58	-	48	101	90	70	58	62	54	48	43
25	MGPM	-	69	-	60	54	49	116	100	88	79	71	65
	MGPL	-	82	-	68	132	118	93	77	80	70	62	55
32	MGPM	-	-	203	-	-	164	182	159	142	127	116	106
	MGPL	-	-	113	-	-	78	130	107	130	114	101	90
40	MGPM	-	-	203	-	-	164	182	159	142	127	116	106
	MGPL	-	-	113	-	-	78	129	106	130	114	101	90
50	MGPM	-	-	296	-	-	245	273	241	216	195	179	164
	MGPL	-	-	120	-	-	83	178	148	148	129	114	102
63	MGPM	-	-	296	-	-	245	273	241	216	195	179	164
	MGPL	-	-	117	-	-	81	176	145	145	126	111	99
80	MGPM	-	-	352	-	-	297	368	329	298	272	251	232
	MGPL	-	-	125	-	-	99	281	240	208	184	163	147
100	MGPM	-	-	515	-	-	445	498	450	410	377	349	325
	MGPL	-	-	138	-	-	108	395	340	297	263	235	211

Max. Torque T (N*m)											
Stroke (mm)											
10	20	25	30	40	50	75	100	125	150	175	200
0.39	0.32	-	0.27	0.24	0.21	0.43	0.36	-	-	-	-
0.78	0.66	-	0.57	0.93	0.85	0.69	0.58	-	-	-	-
0.69	0.58	-	0.49	0.43	0.38	0.69	0.58	-	-	-	-
1.23	1.06	-	0.92	1.53	1.40	1.16	0.99	-	-	-	-
-	1.05	-	0.93	0.83	0.75	1.88	1.63	1.44	1.28	1.16	1.06
-	1.70	-	1.52	3.06	2.87	2.47	2.17	2.38	2.16	1.98	1.82
-	1.76	-	1.55	1.38	1.25	2.96	2.57	2.26	2.02	1.83	1.67
-	2.80	-	2.53	4.67	4.39	3.81	3.36	3.65	3.31	3.02	2.78
-	-	6.35	-	-	5.13	5.69	4.97	4.42	3.98	3.61	3.31
-	-	4.76	-	-	3.86	6.53	5.75	7.10	6.46	5.92	5.47
-	-	7.00	-	-	5.66	6.27	5.48	4.87	4.38	3.98	3.65
-	-	5.24	-	-	4.25	7.19	6.33	7.81	7.11	6.52	6.02
-	-	13.0	-	-	10.8	12.0	10.6	9.50	8.60	7.86	7.24
-	-	7.02	-	-	5.76	12.3	10.9	11.2	10.2	9.40	8.69
-	-	14.7	-	-	12.1	13.5	12.0	10.7	9.69	8.86	8.16
-	-	77.7	-	-	6.35	13.7	12.2	12.5	11.4	10.5	9.65
-	-	22.0	-	-	18.6	22.9	20.5	18.6	17.0	15.6	14.5
-	-	10.3	-	-	9.35	24.8	22.7	20.9	19.4	18.0	16.9
-	-	38.8	-	-	33.5	37.5	33.8	30.9	28.4	26.2	24.4
-	-	13.6	-	-	12.2	41.1	37.9	35.1	32.7	30.5	28.6

# MGP New Compact Tri-rod Cylinder (Ø20 ~ Ø100)



The way to automation

## Overall Dimension

MGP  
Ø12 ~ Ø25

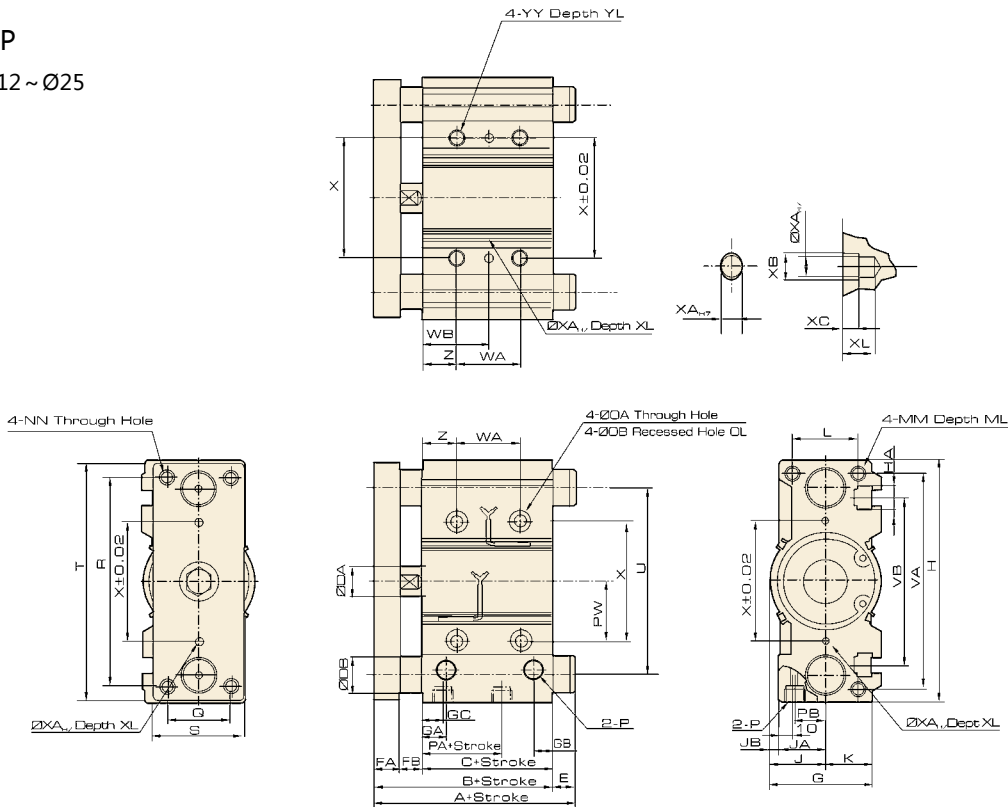

## Dimension

MGPM, MGPL (Ø12 ~ Ø25)

Bore (mm)	Standard Stroke	B	C	DA	FA	FB	G	GA	GB	H	HA	J	K	L	MM	ML	NN	OA	OB	OL	P	PA	PB	PW	Q
12	10,20,30,40	42	29	6	8	5	26	11	7.5	58	M4	13	13	18	M4x0.7	10	M4x0.7	4.3	8	4.5	M5x0.8	13	8	18	14
16	50,75,100	46	33	8	8	5	30	11	8	64	M4	15	15	22	M5x0.8	12	M5x0.8	4.3	8	4.5	M5x0.8	15	10	19	16
20	20,30,40,50,75,100	53	37	10	10	6	36	10.5	8.5	83	M5	18	18	24	M5x0.8	13	M5x0.8	5.6	9.5	5.5	Rc1/8	12.5	10.5	25	18
25	125,150,175,200	53.5	37.5	12	10	6	42	11.5	9	93	M5	21	21	30	M6x1.0	15	M6x1.0	5.6	9.5	5.5	Rc1/8	12.5	13.5	28.5	26

Bore (mm)	Standard Stroke	R	S	T	U	VA	VB	WA			WB			X	XA	XB	XC	XL	YY	YL	Z
								Below 30st	40st to 100st	125st or above	Below 30st	40st to 100st	125st or below								
12	10,20,30,40	48	22	56	41	50	37	20	40	-	15	25	-	23	3	3.5	3	6	M5x0.8	10	5
16	50,75,100	54	25	62	46	56	38	24	44	-	17	27	-	24	3	3.5	3	6	M5x0.8	10	5
20	20,30,40,50,75	70	30	81	54	72	44	24	44	120	29	39	77	28	3	3.5	3	6	M6x1.0	12	17
25	100,125,150,175,200	78	38	91	64	82	50	24	44	120	29	39	77	34	4	4.5	3	6	M6x1.0	12	17

MGPM (Slidable Bearing)

Bore (mm)	A		DB	E	
	Below 50st	Above 50st		Below 50st	Above 50st
12	42	60.5	8	0	18.5
16	46	64.5	10	0	18.5
20	53	84.5	12	0	31.5
25	53.5	85	16	0	31.5

MGPL (Ball Bearing)

Bore (mm)	A			DB	E		
	Below 30st	30st to 100st	100st or Above		Below 30st	30st to 100st	100st or Above
12	43	55	85	6	1	13	43
16	49	65	95	8	3	19	49
20	63	80	104	10	10	27	51
25	69.5	80.5	104.5	13	16	32	51

## Overall Dimension

### MGP

Ø32 ~ Ø63

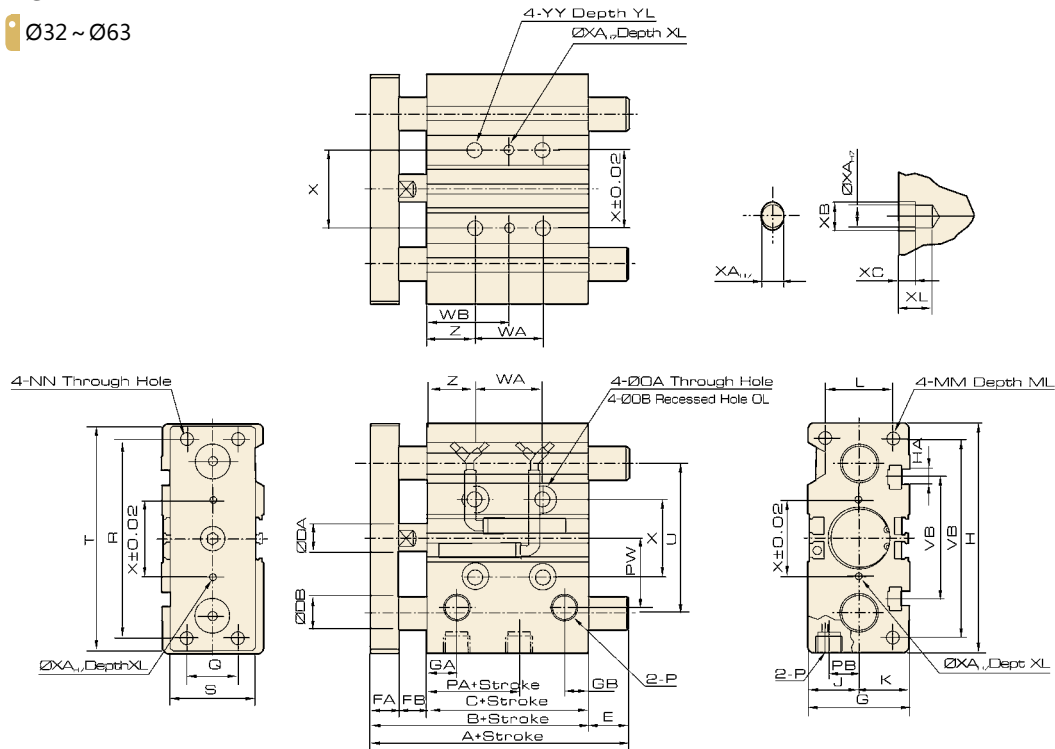

Cylinder  
Sizing  
SI  
SI A.  
SC / SU  
SCT  
SC A.  
DSN  
DSN A.  
MA  
MAL  
MA/MAL A.  
SDA  
CQ2  
CJ2  
CDU  
TN  
CXS  
MGP  
MSQ

## Dimension

MGPM, MGPL (Ø32 ~ Ø63)

Bore (mm)	Standard Stroke	B	C	DA	FA	FB	G	GA	GB	GC	H	HA	J	K	L	MM	ML	NN	OA	OB	OL	P	PA	PB	PW	Q
32	25,50,75, 100,125,150, 175,200	59.5	37.5	16	12	10	48	12.5	112	9	112	M6	24	24	34	M8x1.25	20	M8x1.25	6.6	11	7.5	Rc1/8	7	15	34	30
40		66	44	16	12	10	54	14	120	10	120	M6	27	27	40	M8x1.25	20	M8x1.25	6.6	11	7.5	Rc1/8	13	18	38	30
50		72	44	20	16	12	64	12	148	11	148	M8	32	32	46	M10x1.5	22	M10x1.5	8.6	14	9	Rc1/4	9	21.5	47	40
63		77	49	20	16	12	78	16.5	162	13.5	162	M10	39	39	58	M10x1.5	22	M10x1.5	8.6	14	9	Rc1/4	14	28	55	50

Bore (mm)	Standard Stroke	R	S	T	U	VA	VB	WA			WB			X	XA	XB	XC	XL	YY	YL	Z
								25st	50,75,100st	Above 100st	25st	50,75,100st	Above 100st								
32	25,50,75, 100,125, 150,175,200	96	44	110	78	98	63	24	48	124	33	45	83	42	4	4.5	3	6	M8x1.25	16	21
40		104	44	118	86	106	72	24	48	124	34	46	84	50	4	4.5	3	6	M8x1.25	16	22
50		130	60	146	110	130	92	24	48	124	36	48	86	66	5	6	4	8	M10x1.5	20	24
63		130	70	158	124	142	110	28	52	128	38	50	88	80	5	6	4	8	M10x1.5	20	24

### MGPM (Slidable Bearing)

Bore (mm)	A		DB	E	
	25,50st	Above 50st		Below 25,50st	Above 50st
32	97	102	20	37.5	42.5
40	97	102	20	31	36
50	106.5	118	25	34.5	46
63	106.5	118	25	29.5	41

### MGPL (Ball Bearing)

Bore (mm)	A			DB	E		
	50st	75,100st	Above 100st		50st	75,100st	Above 100st
32	81	98	118	16	21.5	38.5	58.5
40	81	98	118	16	15	32	52
50	93	114	134	20	21	42	62
63	93	114	134	20	16	37	57

# MGP New Compact Tri-rod Cylinder (Ø20 ~ Ø100)



The way to automation

- Cylinder
- Sizing
- SI
- SI A.
- SC / SU
- SCT
- SC A.
- DSN
- DSN A.
- MA
- MAL
- MA/MAL A.
- SDA
- CQ2
- CJ2
- CDU
- TN
- CXS
- MGP**
- MSQ

## Overall Dimension

### MGP

Ø80 ~ Ø100

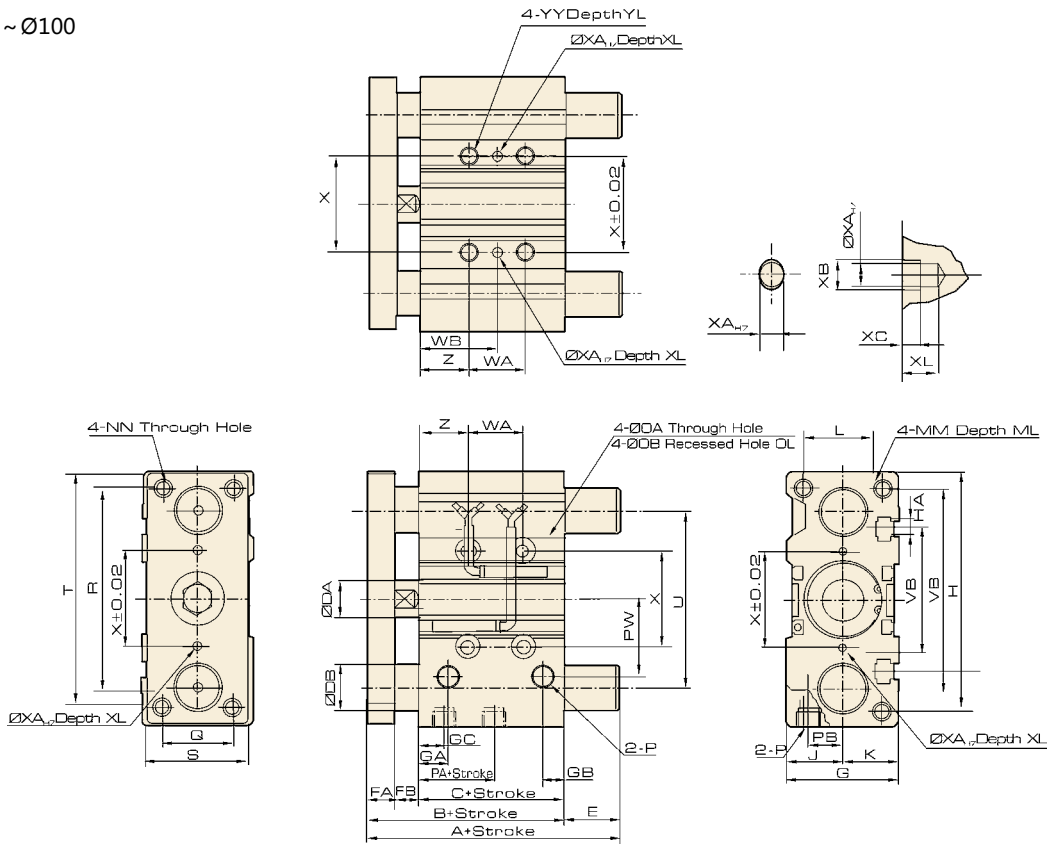

## Dimension

MGPM, MGPL Dimension (Ø80 ~ Ø100)

Bore (mm)	Standard Stroke	B	C	DA	FA	FB	G	GA	GB	GC	H	HA	J	JA	JB	K	L	MM	ML	NN	OA	OB	OL	P	PA	PB	PW	Q
80	25,50,75,	96.5	56.5	25	22	18	91.5	19	15.5	14.5	202	M12	45.5	38	7.5	46	54	M12x1.75	30	M12x1.75	10.6	17.5	8	Rc3/8	14.5	25.5	74	52
100	100,125,150, 175,200	116	66	30	25	25	111.5	23	19	18	240	M14	55.5	45	10.5	56	62	M14x2.0	32	M14x2.0	12.5	20	8	Rc3/8	17.5	32.5	89	64

Bore (mm)	Standard Stroke	R	S	T	U	VA	VB	WA			WB			X	XA	XB	XC	XL	YY	YL	Z
								25st	50,75,100st	Above 100st	25st	50,75,100st	Above 100st								
80	25,50,75,	174	75	198	156	180	140	28	52	128	42	54	92	100	6	7	5	10	M12x1.75	24	28
100	100,125,150, 175,200	210	90	236	188	210	166	48	72	148	35	47	85	124	6	7	5	10	M14x2.0	28	11

### MGPM (Slidable Bearing)

Bore (mm)	A		DB	E	
	25,50st	Above 50st		Below 25,50st	Above 50st
80	115	142	30	18.5	45.5
100	137	162	36	21	46

### MGPL (Ball Bearing)

Bore (mm)	A			DB	E		
	25,50st	75,100st	Above 100st		25,50st	75,100st	Above 100st
80	109.5	130	160	25	13	33.5	63.5
100	121	147	180	30	5	31	64