

4V100 Series

Solenoid Valve, Air Piloted Valve



The way to automation

Valve

4V100

4V200

4V300

4V400

Manifold

3V1

JEL

JZF

MVSD

VF, VZ

BM, PU, AM

Diaphragm

Coil

2V

2W

2W(Big)

2P

2L

VX

PU

PU225

2Q

JEL5404

JEL6213

Pulse

JELJZF

4H

TSV

MPV

4HV

HV, K

4R

4F

MSV

JM

ASC, RE

QE, QEA

ST

HSV



Ordering Code

4V	1	10	06	B	AC220V	W	F
Specification	Series Code	Coil and Type	Port size	Connection and Initial status	Standard Voltage	Wiring	Joint
4V: 5/2 (3) way solenoid valve 4A: 5/2 (3) way air pilot valve 3V: 3/2 way solenoid valve 3A: 3/2 way air pilot valve	1: 100 Series	10: Single coil 20: Double coil 30C: Mid-position closed 30E: Mid-position vented 30P: Mid-position open	M5: M 5 × 0.8 06: 1/8"	Blank: Threaded B: Sub-plated mounted (for 5/2,5/3 way only) NC: 3/2 way normally closed NO: 3/2 way normally open	DC12V DC24V AC24V 50Hz/60Hz AC110V 50Hz/60Hz AC220V 50Hz/60Hz AC380V 50Hz/60Hz	Blank: Without light indicator LD: Brown with light indicator LD1: White with light indicator W: Lead wire	1 F-20 F

Specification

Model	4V110-M5	4V120-M5	4V130C-M5	4V130E-M5	4V130P-M5	4V110-06	4V120-06	4V130C-06	4V130E-06	4V130P-06
	4A110-M5	4A120-M5	4A130C-M5	4A130E-M5	4A130P-M5	4A110-06	4A120-06	4A130C-06	4A130E-06	4A130P-06
Valve Type	5/2 way		5/3 way			5/2 way		5/3 way		
Effective Cross Section Area	10 mm ² (CV = 0.56)		7 mm ² (CV = 0.40)			12 mm ² (CV = 0.67)		9 mm ² (CV = 0.5)		
Model	3V110-M5	3V120-M5	3A110-M5	3A120-M5	3V110-06	3V120-06	3A110-06	3A120-06		
Valve Type	3/2 way									
Effective Cross Section Area	10 mm ² (CV = 0.56)					12 mm ² (CV = 0.67)				
Port Size	Inlet, Outlet, Exhaust Port = M5 × 0.8					Inlet, Outlet, Exhaust Port = G 1/8"				
Working Medium	40 Micron Filtered Air									
Operation	Internal piloted									
Working-pressure	0.15 ~ 0.8 MPa									
Max. Test Pressure	1.2 MPa									
Ambient Temperature	5 ~ 50 °C									
Operating Voltage Tolerance	± 10%									
Power Consumption	AC: 2.8 VA DC: 2.8 W									
Connector Protection	F Class, IP 65									
Wiring / Connector	Cable / Lead Wire or DIN Connector									
Switching Frequency	5 Cycles / Sec.									
Response Time	0.05 Sec.									

Overall Dimension

4V110-M5

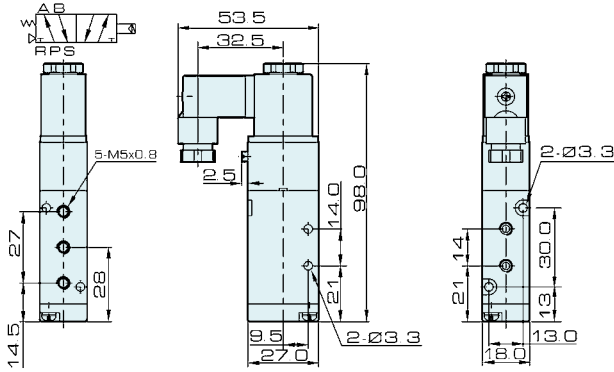

4V110-06

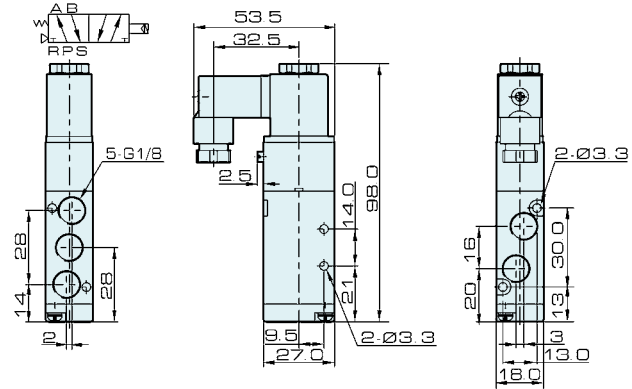

4V120-M5

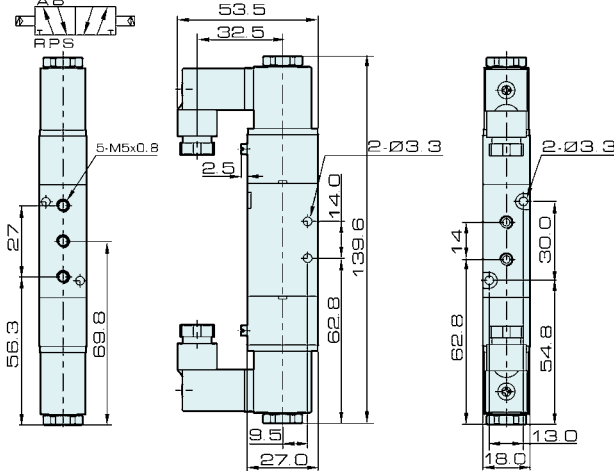

4V120-06

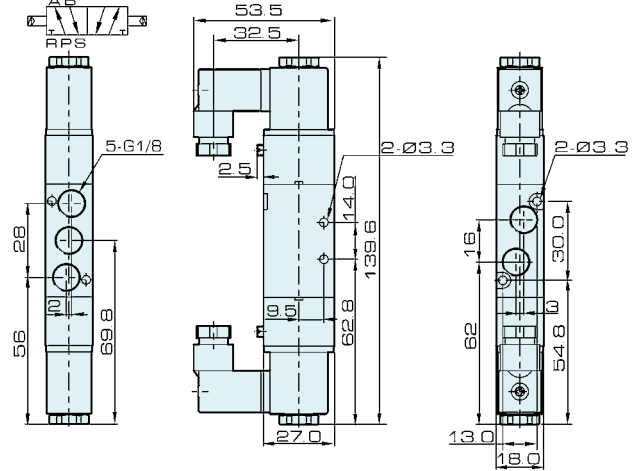

4V130-M5

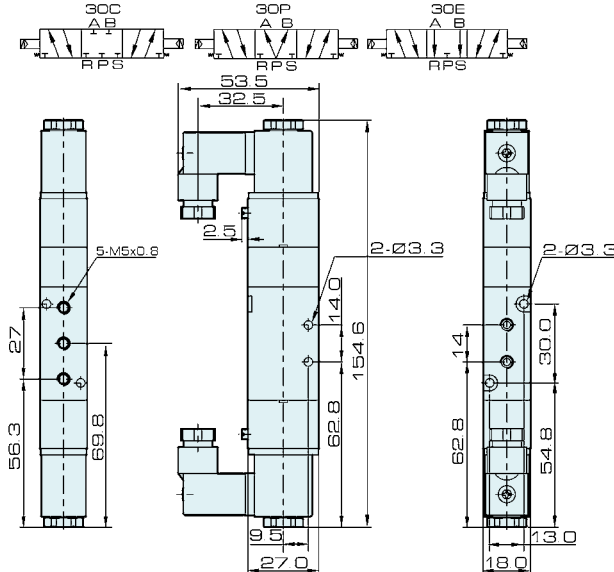

4V130-06

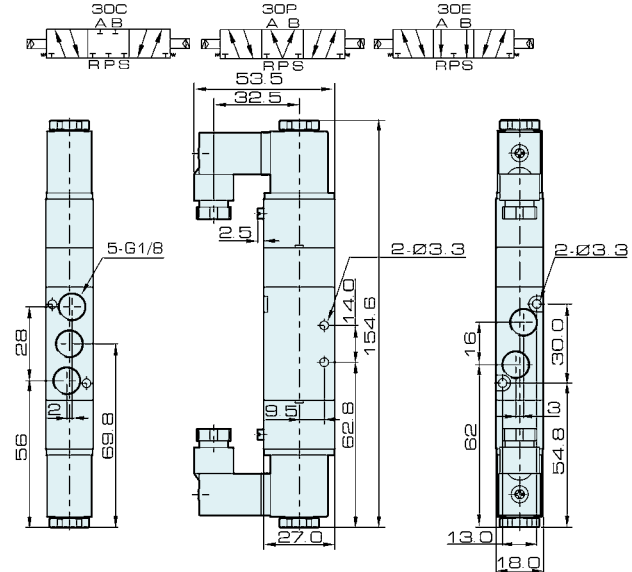

Valve

4V100

4V200

4V300

4V400

Manifold

3V1

JEL

JZF

MVSD

VF, VZ

BM, PU, AM

Diaphragm

Coil

2V

2W

2W(Big)

2P

2L

VX

PU

PU225

2Q

JEL5404

JEL6213

Pulse

JEL, JZF

4H

TSV86

MPV

4HV

HV, K

4R

4F

MSV

JM

ASC, RE

QE, QEA

ST

HSV

4V100 Series

Solenoid Valve, Air Pilot Valve



The way to automation

Overall Dimension

- Valve
- 4V100
- 4V200
- 4V300
- 4V400
- Manifold
- 3V1
- JEL
- JZF
- MVSD
- VF, VZ
- BM, PU, AM
- Diaphragm
- Coil
- 2V
- 2W
- 2W(Big)
- 2P
- 2L
- VX
- PU
- PU225
- 2Q
- JEL5404
- JEL6213
- Pulse
- JELJZF
- 4H
- TSV
- MPV
- 4HV
- HV, K
- 4R
- 4F
- MSV
- JM
- ASC, RE
- QE, QEA
- ST
- HSV

4A110-M5

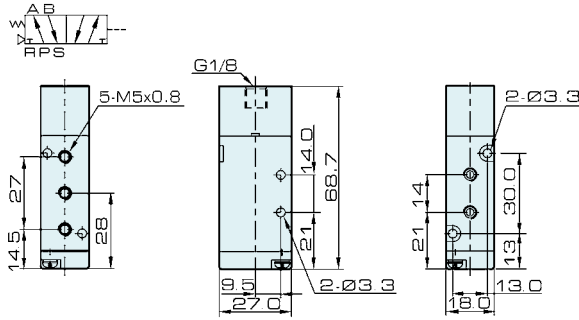

4A110-06

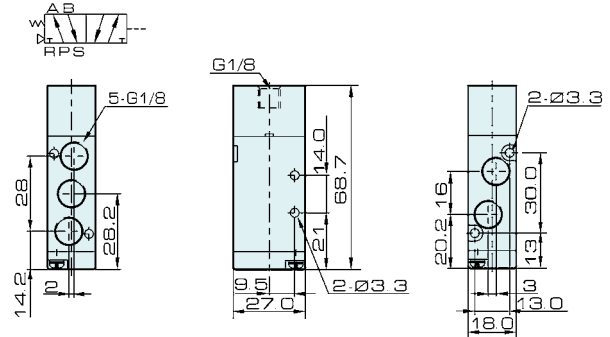

4A120-M5

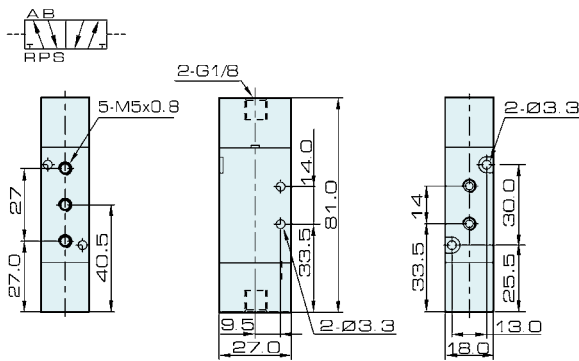

4A120-06

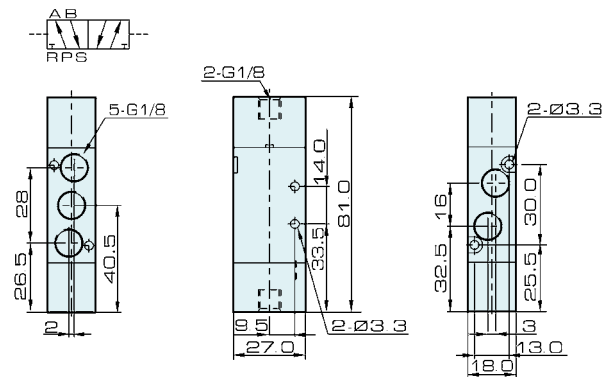

4A130-M5

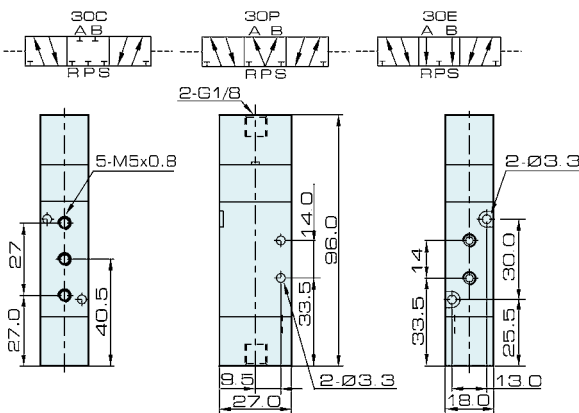

4A130-06

