

CE  
ISO9001:2000

# 4V300 Series

## Solenoid Valve, Air Piloted Valve



Valve  
4V100  
4V200  
4V300  
4V400  
Manifold  
3V1  
JEL  
JZF  
MVSD  
VF, VZ  
BM, PU, AM  
Diaphragm  
Coil  
2V  
2W  
2W(Big)  
2P  
2L  
VX  
PU  
PU225  
2Q  
JEL5404  
JEL6213  
Pulse  
JEL, JZF  
4H  
TSV86  
MPV  
4HV  
HV, K  
4R  
4F  
MSV  
JM  
ASC, RE  
QE, QEA  
ST  
HSV

### Ordering Code

4V	3	10	10	B	AC220V	W	F
Specification	Series Code	Coil and Type	Port size	Connection and Initial status	Standard Voltage	Wiring	Joint
4V: 5/2 (3) way solenoid valve 4A: 5/2 (3) way air pilot valve 3V: 3/2 way solenoid valve 3A: 3/2 way air pilot valve	300 Series	10: Single coil 20: Double coil 30C: Mid-position closed 30E: Mid-position vented 30P: Mid-position open	08: 1/4" 10: 3/8"	Blank: Threaded B: Sub-plated mounted (for 5/2;5/3 way only) NC: 3/2 way normally closed NO: 3/2 way normally open	DC12V DC24V AC24V 50Hz/60Hz AC110V 50Hz/60Hz AC220V 50Hz/60Hz AC380V 50Hz/60Hz	Blank: Without light indicator LD: Brown with light indicator LD1: White with light indicator W: Lead wire	1 F-20 F

### Specification

Model	4V310-08	4V320-08	4V330C-08	4V330E-08	4V330P-08	4V310-10	4V320-10	4V330C-10	4V330E-10	4V330P-10
Valve Type	5/2 way		5/3 way			5/2 way		5/3 way		
Effective Cross Section Area	25 mm <sup>2</sup> (CV = 1.40)		18 mm <sup>2</sup> (CV = 1.00)			30 mm <sup>2</sup> (CV = 1.68)		18 mm <sup>2</sup> (CV = 1.00)		
Model	3V310-08	3V320-08	3A310-08	3A320-08	3V310-10	3V320-10	3A310-10	3A320-10		
Valve Type	3/2 way									
Effective Cross Section Area	25 mm <sup>2</sup> (CV = 1.40)					30 mm <sup>2</sup> (CV = 1.68)				
Port Size	Supply, Outlet, Exhaust Port = G 1/4"					Supply, Outlet, Exhaust Port = G 1/4"				
Working Medium	40 Micron Filtered Air									
Operation	Internal piloted									
Working-pressure	0.15 ~ 0.8 MPa									
Max. Test Pressure	1.2 MPa									
Ambient Temperature	5 ~ 50 °C									
Operating Voltage Tolerance	± 10%									
Power Consumption	AC: 5.5 VA DC: 4.8 W									
Connector Protection	F Class, IP 65									
Wiring/Connector	Cable / Lead Wire or DIN Connector									
Switching Frequency	5 Cycles / Sec.									
Response Time	0.05 Sec.									

# 4V300 Series

## Solenoid Valve, Air Piloted Valve



The way to automation

### Overall Dimension

- Valve
- 4V100
- 4V200
- 4V300
- 4V400
- Manifold
- 3V1
- JEL
- JZF
- MVSD
- VF, VZ
- BM, PU, AM
- Diaphragm
- Coil
- 2V
- 2W
- 2W(Big)
- 2P
- 2L
- VX
- PU
- PU225
- 2Q
- JEL5404
- JEL6213
- Pulse
- JELJZF
- 4H
- TSV
- MPV
- 4HV
- HV, K
- 4R
- 4F
- MSV
- JM
- ASC, RE
- QE, QEA
- ST
- HSV

#### 4V310-08

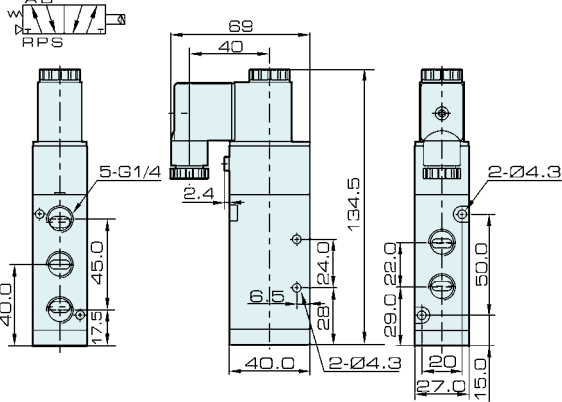

#### 4V310-10

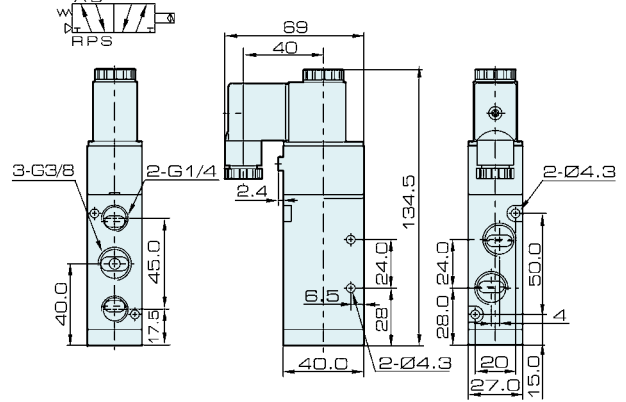

#### 4V320-08

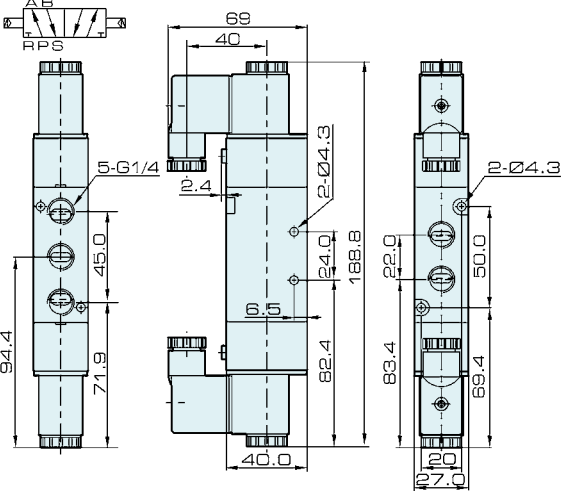

#### 4V320-10

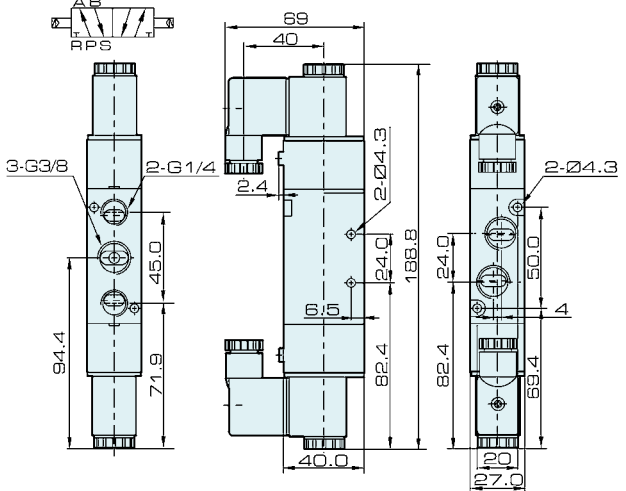

#### 4V330-08

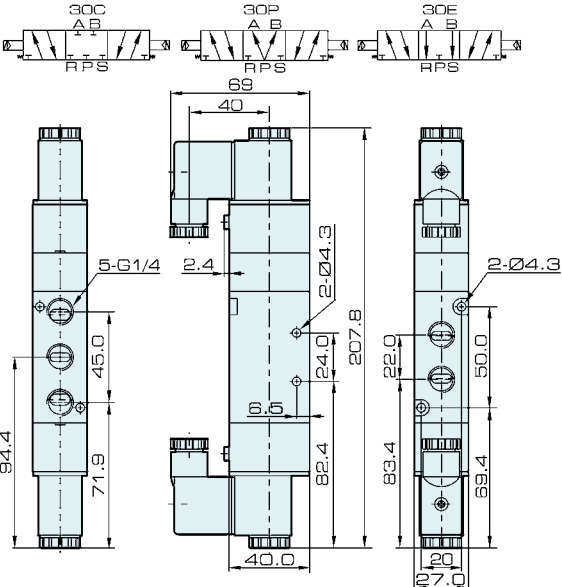

#### 4V330-10

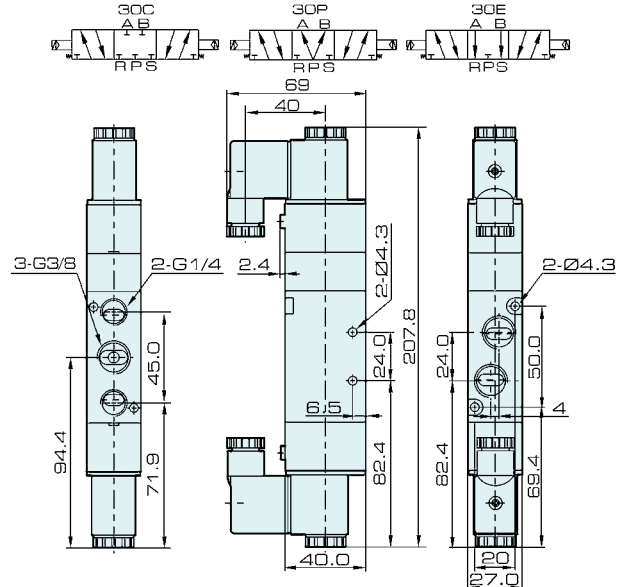

### Overall Dimension

4V310-08B

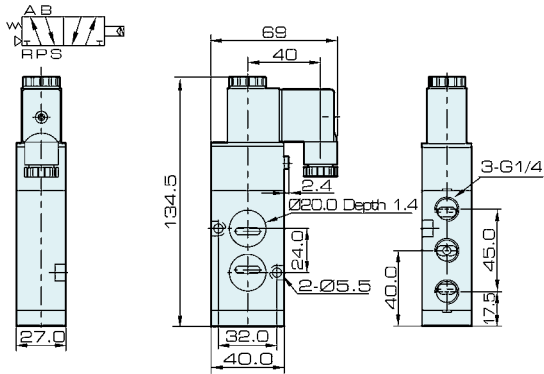

4V310-10B

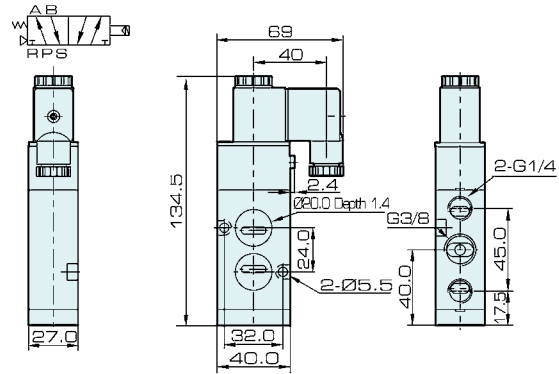

4V320-08B

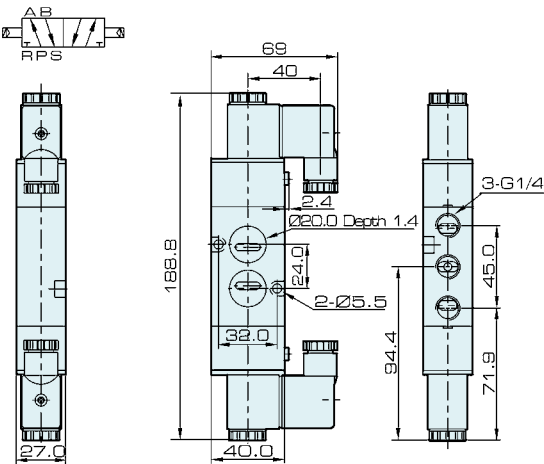

4V320-10B

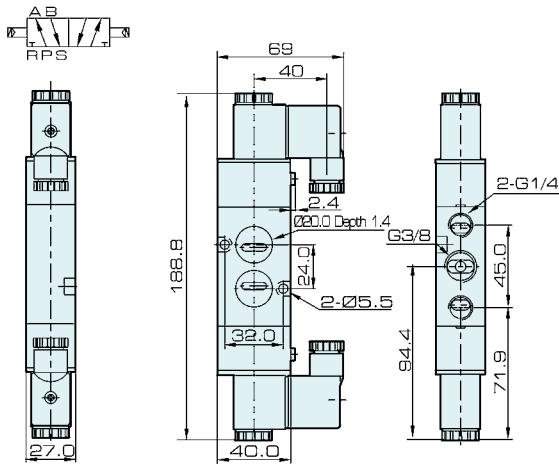

4V330-08B

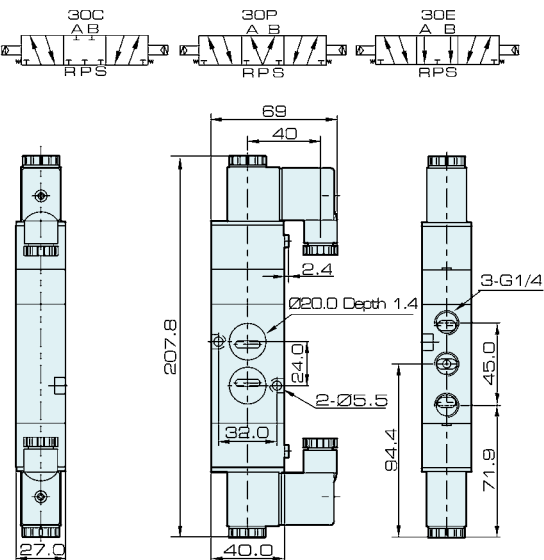

4V330-10B

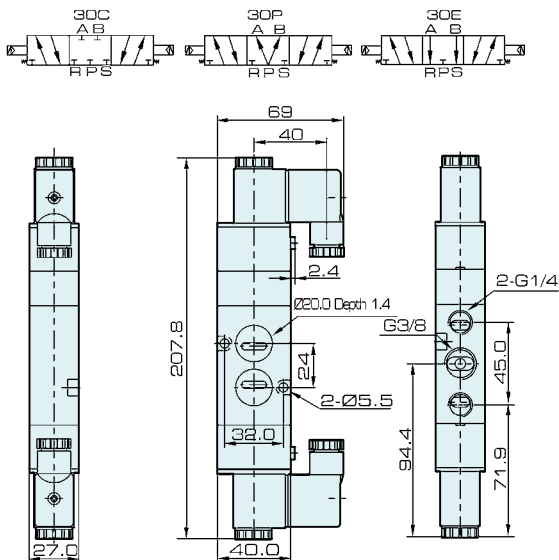

Valve

4V100

4V200

4V300

4V400

Manifold

3V1

JEL

JZF

MVSD

VF, VZ

BM, PU, AM

Diaphragm

Coil

2V

2W

2W(Big)

2P

2L

VX

PU

PU225

2Q

JEL5404

JEL6213

Pulse

JEL, JZF

4H

TSV86

MPV

4HV

HV, K

4R

4F

MSV

JM

ASC, RE

QE, QEA

ST

HSV

# 4V300 Series

## Solenoid Valve, Air Piloted Valve



The way to automation

### Overall Dimension

- Valve
- 4V100
- 4V200
- 4V300
- 4V400
- Manifold
- 3V1
- JEL
- JZF
- MVSD
- VF, VZ
- BM, PU, AM
- Diaphragm
- Coil
- 2V
- 2W
- 2W(Big)
- 2P
- 2L
- VX
- PU
- PU225
- 2Q
- JEL5404
- JEL6213
- Pulse
- JELJZF
- 4H
- TSV
- MPV
- 4HV
- HV, K
- 4R
- 4F
- MSV
- JM
- ASC, RE
- QE, QEA
- ST
- HSV

#### 4A310-08

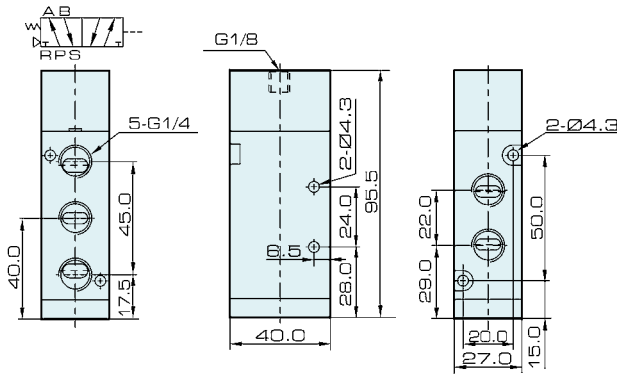

#### 4A310-10

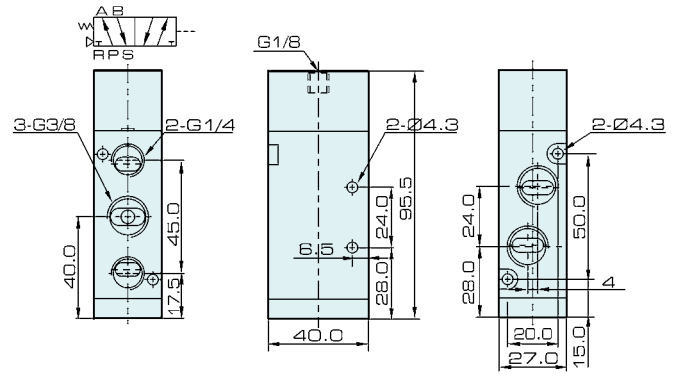

#### 4A320-08

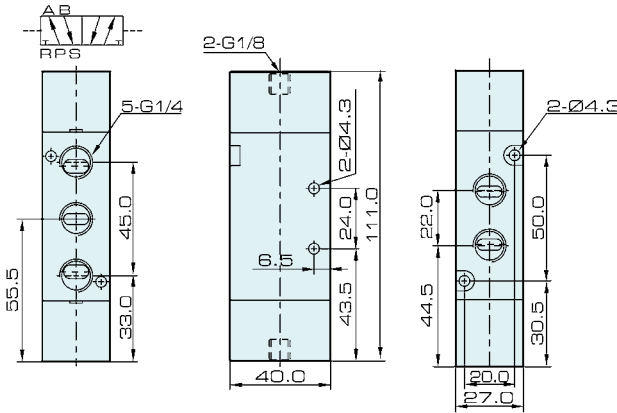

#### 4A320-10

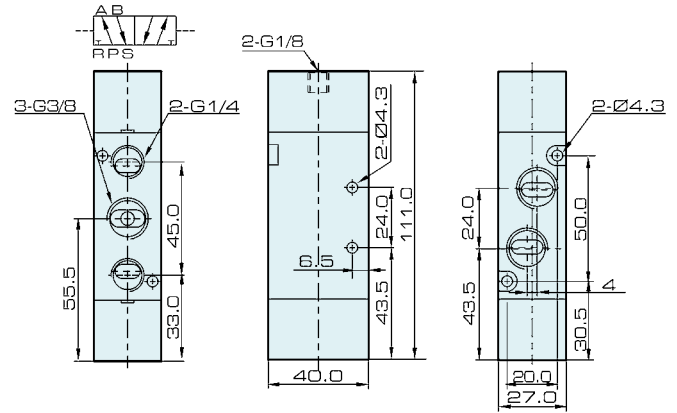

#### 4A330-08

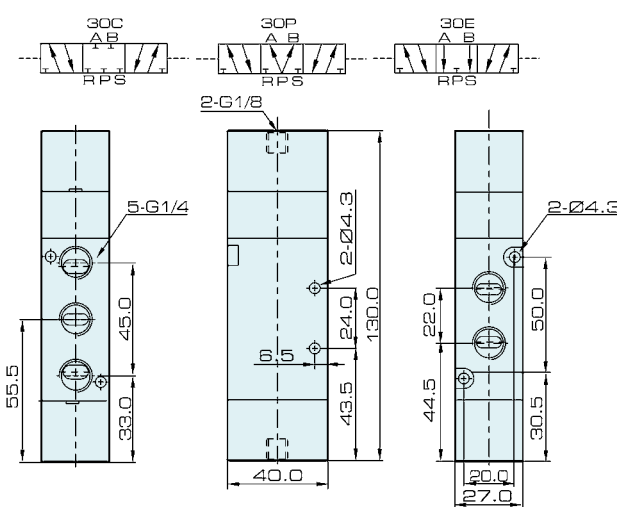

#### 4A330-10

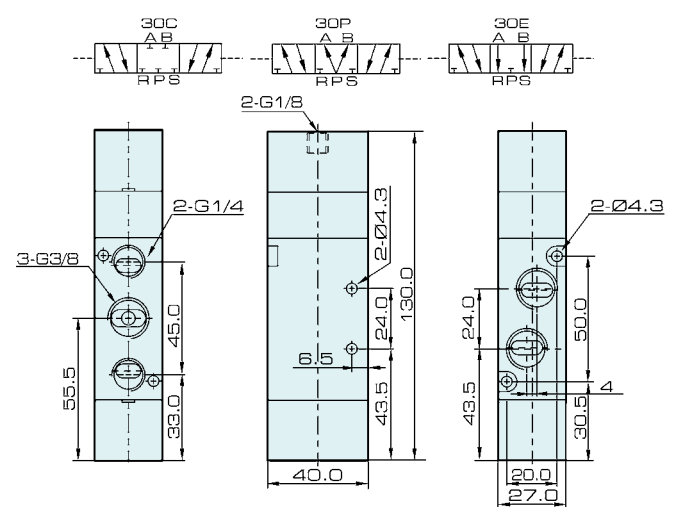

### Overall Dimension

3V310-08

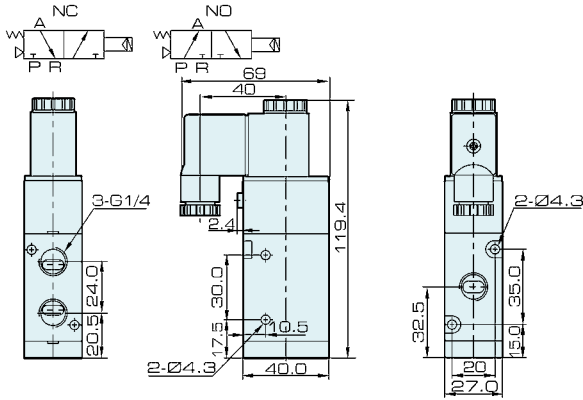

3V310-10

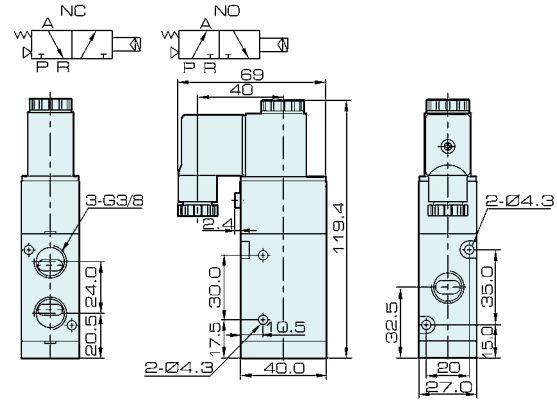

3V320-08

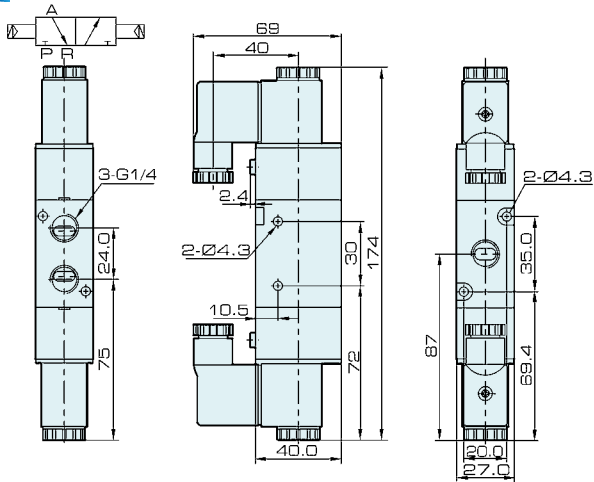

3V320-10

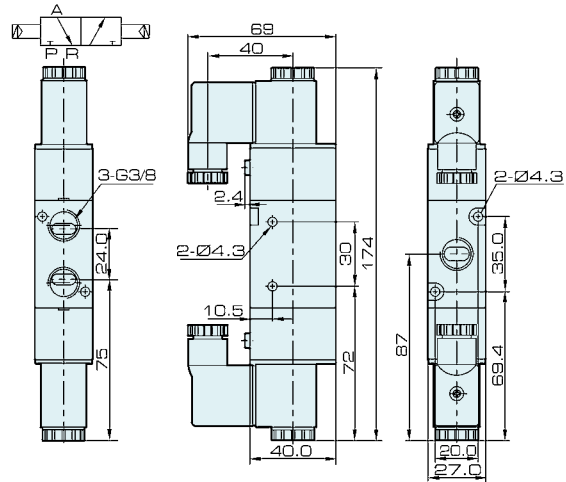

3A310-08

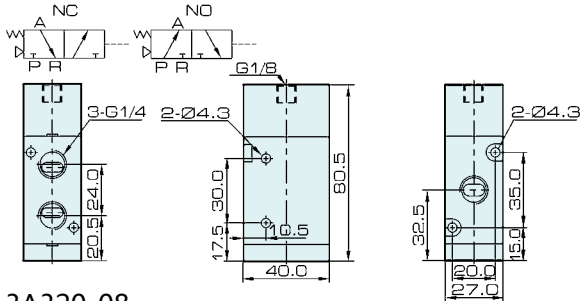

3A310-10

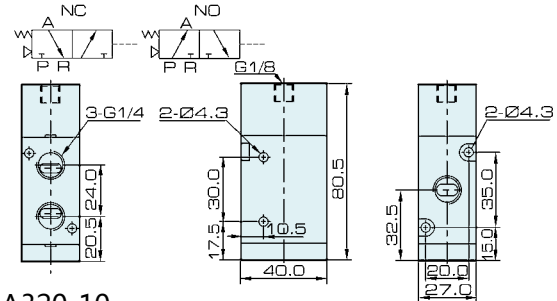

3A320-08

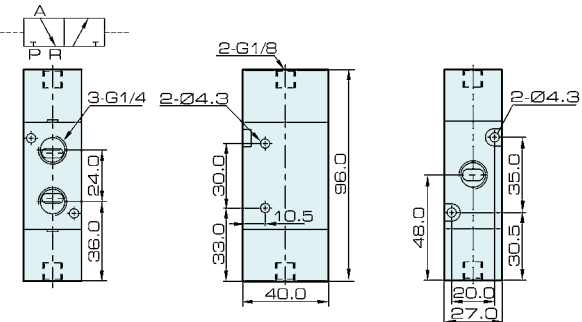

3A320-10

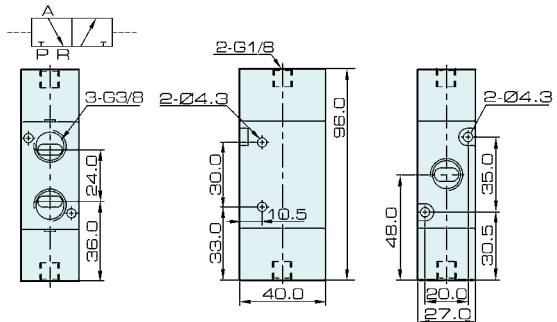

### Valve

4V100

4V200

4V300

4V400

Manifold

3V1

JEL

JZF

MVSD

VF, VZ

BM, PU, AM

Diaphragm

Coil

2V

2W

2W(Big)

2P

2L

VX

PU

PU225

2Q

JEL5404

JEL6213

Pulse

JEL, JZF

4H

TSV86

MPV

4HV

HV, K

4R

4F

MSV

JM

ASC, RE

QE, QEA

ST

HSV